

Indian Institute of Science

Design of Photovoltaic Systems

Prof. L. Umanand

**Department of Electronic Systems Engineering
Indian Institute of Science, Bangalore**

NPTEL Online Certification Course

(Refer Slide Time: 00:17)

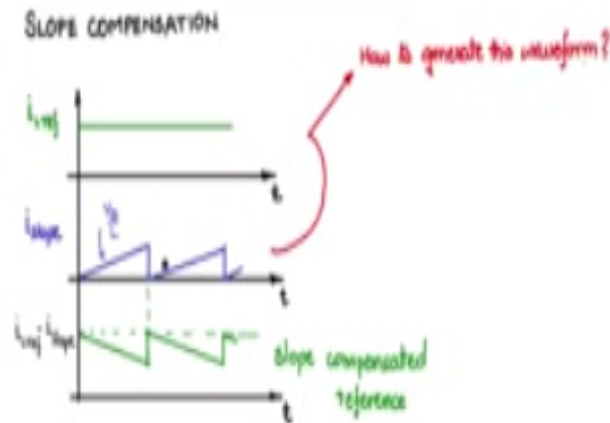

Let us now try to understand what is slope compensation, it is how to obtain the slope compensated reference waveform. Let us understand it with the help of some waveforms with respect to time, I will plot I_L ref which is nothing but a constant DC value. So the inductor current waveform is compared with this constant DC and then that is how the current controlled output is generated.

But this has a problem for greater than 50% duty cycle where it would become unstable. So therefore, we need to generate a slope compensated waveform, let me now draw this type of wave shape. And this slope should be V_B/L should have a magnitude of V_B/L , so this will have a magnitude of V_B/L and this is called I slope let us say. And the new reference will be $I_L - I$ slope and that will look like this.

So this will be the new current reference that we need to use for doing the current control, so the inductor current should get compared with this slope compensated current reference. So this will be the slope compensated reference that we will use now how do we get this wave shape where the slope is same as V_B/L that is the down slope of the inductor current wave from so the question how to generate this wave from, so if we look at the inductor current.

(Refer Slide Time: 02:44)

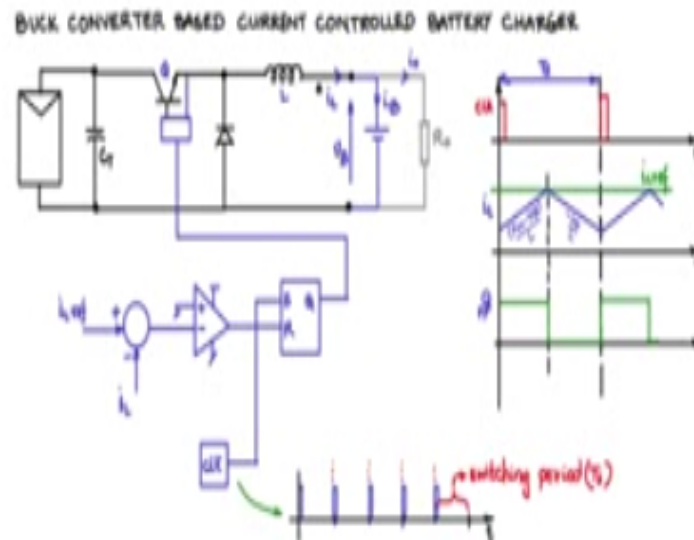

The inductor current here what we have drawn during $1-DT$ period during the time and the switches of the slope of the inductor current is $-V_0/L$ on $-V_B/L$ on the magnitude of that slope is V_B/L so this inductor we by the faraday equation the V_L voltage across the inductor is given by $L \frac{di_L}{dt}$.

(Refer Slide Time: 03:14)

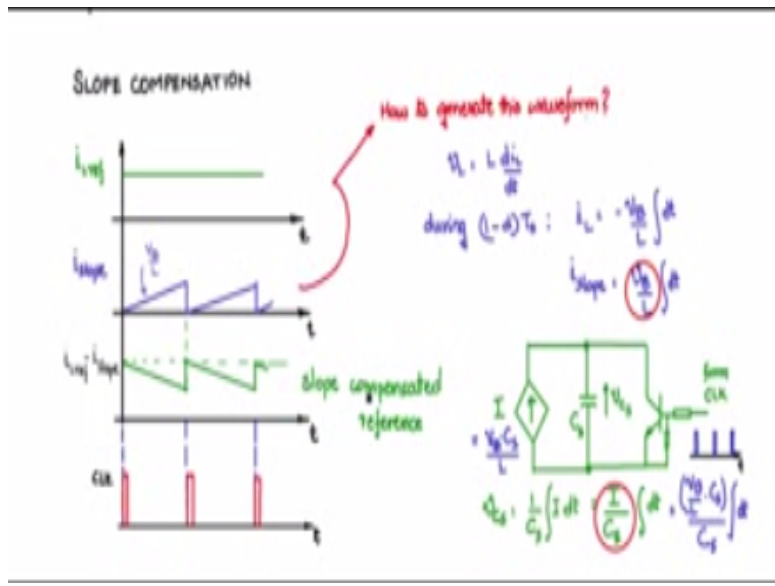

Let us write that down $V_L = L \frac{di_L}{dt}$ and during the $(1-d)T_s$ period i_L is $-\frac{V_P}{L} \int dt$ and I slope because here you're talking of a positive slope by removing the negative sign, taking one considering only the magnitude of the slope will be V_P/L . The integral $\int dt$ so how do we obtain this current wave shape? How do we connect this wave here by implementation? So what we can have is we have a controlled current source like this and that controlled current source is connected to a capacitor like this and let us say C_S is the capacitance and then you can monitor the voltage we V_{CS} across here, and let us say there is a current I that you have decided of the current source so what are the voltage across the capacitance so the voltage of the capacitance is $1/C$ as integral of IDT .

Which is I/C_S because I is constant integral of DT now absorbed this and this the coefficients of integral DT V_P/L and I/C_S now comparing these two comparing these two we can write I as V_P/L into C_S now let us make I here V_P/L into C_S / C_S into DT would be the voltage across this capacitance, so the voltage across this capacitance will follow in this wave shape so voltage equivalent value of a slope will follow this wave shape with this exact slope V_P/L a C_S will come now this with an integrator and as long as the current here is constant this will keep on integrating.

It will not come down to 0 so there has to be a reset mechanism so let us connect across this switch so the current source I will set it at $V_P C_S / L$ now I will connect a switch there across the capacitance and drive that switch on or off from the clock, so whenever there is a clock so that

will switch this on it will discharge this capacitance bring it to 0, so during the period of clock duty cycle this will come down to 0, then again it starts integrating and at this point clock will come into the picture this will come down to 0.

The clock wave form looks like this we have seen this earlier it is a set of narrow pulses occurring at every t_s period at the beginning of every t_s period is a very, very narrow duty cycle pulse and it is during this very narrow duty cycle it will turn on this switch short circuit the capacitance the capacitance discharge through this one, you can put a resistance and series a small resistance and series to probably limit the current.

Now this if you place it along with these set of wave forms it will look in this fashion so let me draw so these are the positions when the clock will appear so you will see the clock signal so a very narrow duty cycle pulse occurring at the start of every t_s period it will reset the capacitance and then bring to 0 then the capacitance will keep integrating it will build up and at the occurs of the next clock it will reset to 0 again it will start integrating and the occurrence of the next clock starting of the t_s period it will reset to 0 so this will keep happening so in this way we can generate this high slope wave form and use it for obtaining the slope compensated reference.

(Refer Slide Time: 08:15)

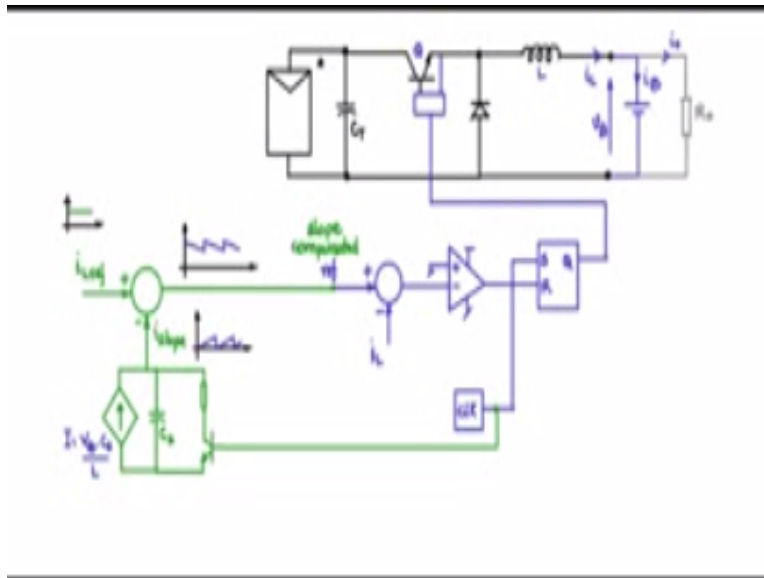

Now let us take our current controlled convertor charges circuit earlier we had i_L from directly here i_L here was a constant p_c value so we will replace it with these slope compensated reference so what we will do is that we will remove i_L there and I will say that this point we are going to give a slope compensated reference.

Now how do we generate that let us how i_L here should be back a bit and I will compare it with this i_L slope so let me have a controlled current source this control current source will have a current value I which is dependent on the sensed value of $V_b/L \cdot C_s$ so put a capacitance there and across the capacitance.

I will put as switch and this switch I will turn on based on this clock signal so whenever the clock used high this will also turn it is on reset this capacitor and then when this goes off this will start integrating this resistance is put here just to limit the current and it will also put in a time constant $C_s \cdot R$ time constant into the picture.

But it will be a small time constant which will reach 5 times constant by the time the clock would decide duty cycle pulse finishes, so this value what you will be giving there is i_{slope} and you – it from i_{ref} and give this as the compensated slope reference. Now if you look at this wave shape this is just a DC and what about this wave shape, so let us first set the current reference here and the current value is $V_B \times C_S / l$ observe that V_B si the sensed value. So the current reference here will change according to the output voltage here.

And if you do that then here you will get a positive slopes form like this i_{ref} – will give you a wave form like this and this will form the slope compensated references that you will provide to this controller. So now if whenever it is $>$ this it is slope compensated value than the other will negative and this will go positive and reset the S or latch. So this is how the slope compensated current controller will work and charge the battery.

Now this i_{ref} here if it is coming from the output of the MPPT charger that is you are sensing the voltage and the current from here and passes through the hill deduction or hill climbing algorithm, output of that you give it out here, then the current reference here will keep changing according to whatever peak power the PV panel can deliver and as those reference changes you will see that current here will increase or decrease depending upon the isolation value than that becomes a MPPT based slope compensated current controller battery charger for PV source including the MPPT block we can include the MPPT algorithm block here as similar to the hill climbing algorithm it needs two input one input is V_T the terminal voltage of the PV panel the other input is high PV.

The current flowing through the panel and the output of the MPPT we will get it I_L reference here so this value will change as we saw earlier in the fashion and I_L refer will keep changing in depending upon insulation and it will right to draw set the I_L reference here such that maximum power can be drawn from the PV panel so as this I_L reference get set and the slope compensated current convertor will make I_L value same as the I_L reference and there by charger the battery and the load together at the best power available from the PV source.